

# FoveaCam++: Systems-Level Advances for Long Range Multi-object High-Resolution Tracking

Yuxuan Zhang, Sanjeev Koppal

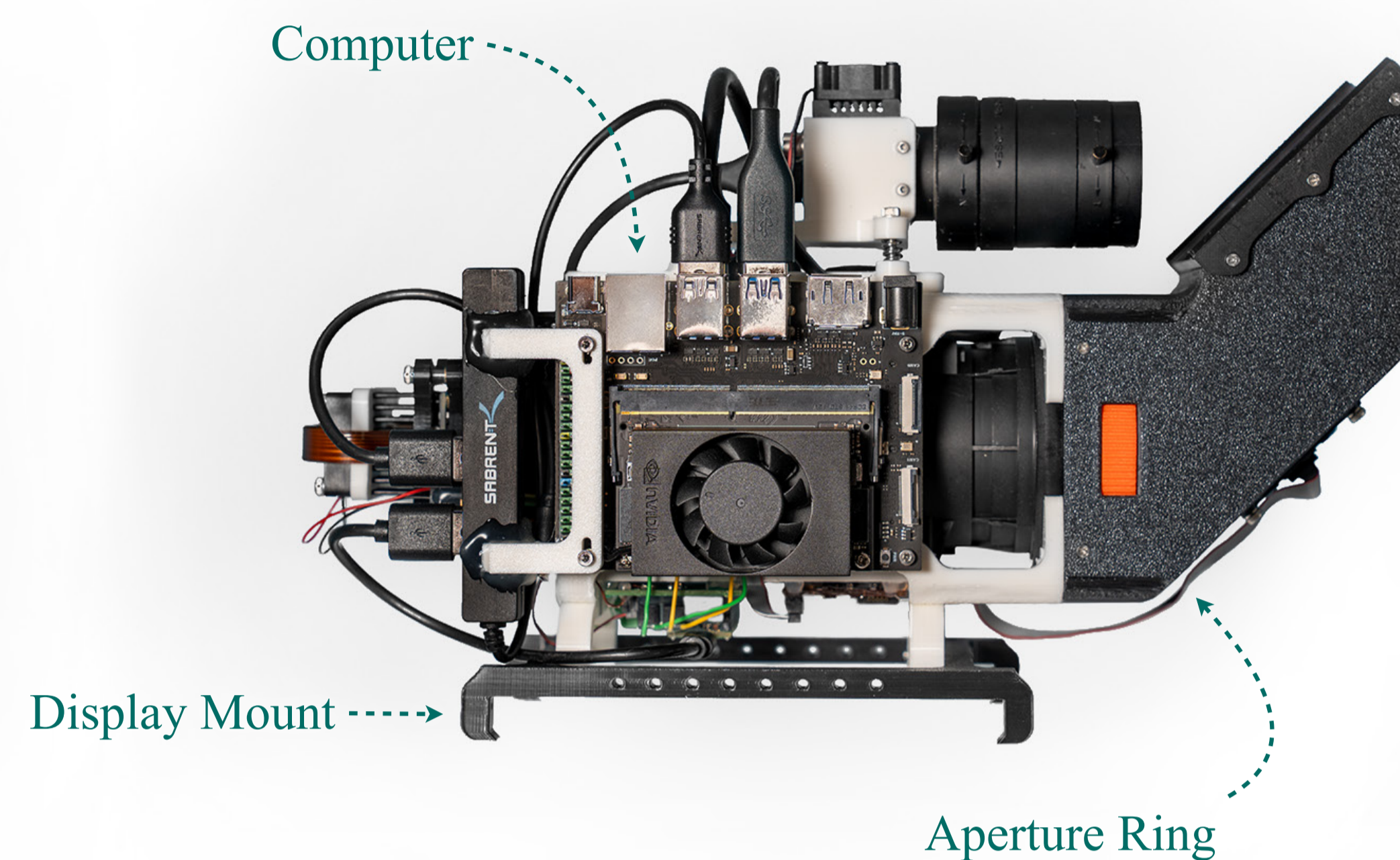
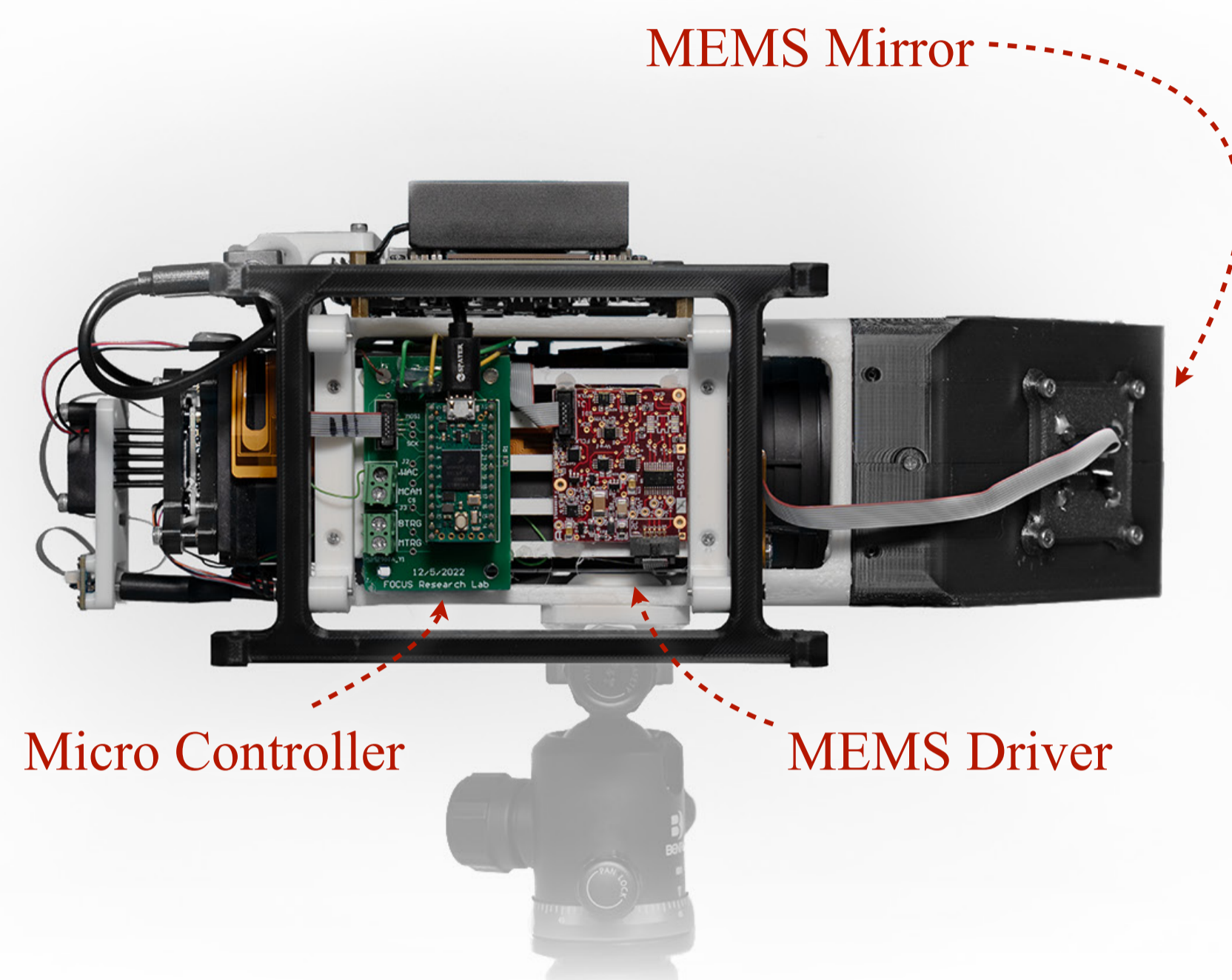
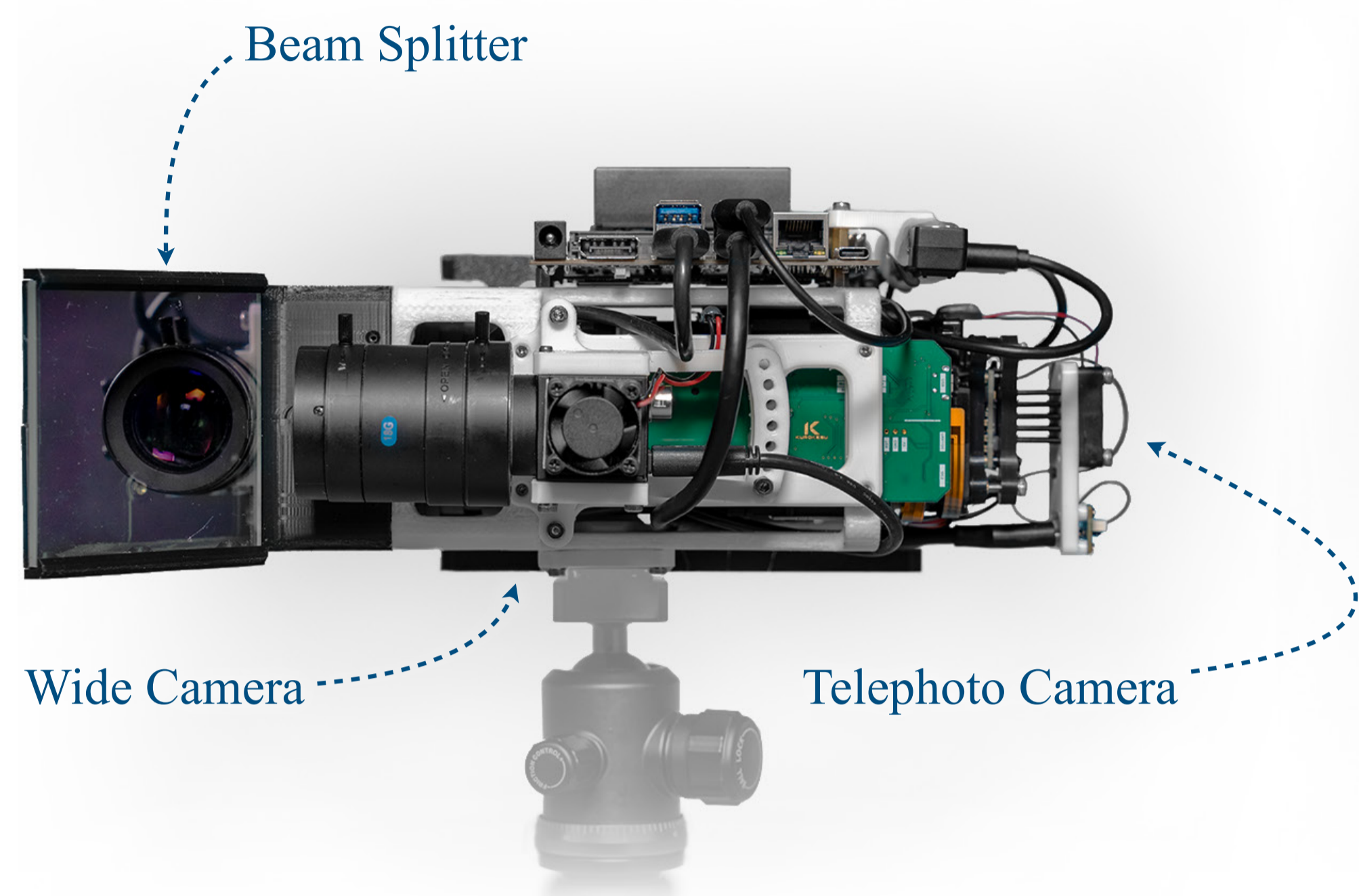

ABSTRACT

UAVs and other fast moving robots needs to keep track of distant objects. Conventional zoom cameras commit to a particular viewpoint, and carrying multiple zoom cameras for multi-object tracking is not feasible for power limited robotic systems. We present a dual camera setup that allows tracking of multiple targets at nearly 1km distance with high-resolution. Our setup includes a wide angle camera (WAC) providing a conventional resolution view and a MEMS driven zoom camera that can query a specific region within the WAC. We built and calibrated the two-camera system and implemented a real-time image fusion pipeline. We show multi-object tracking and stabilization in real world scenarios.

## Calibration

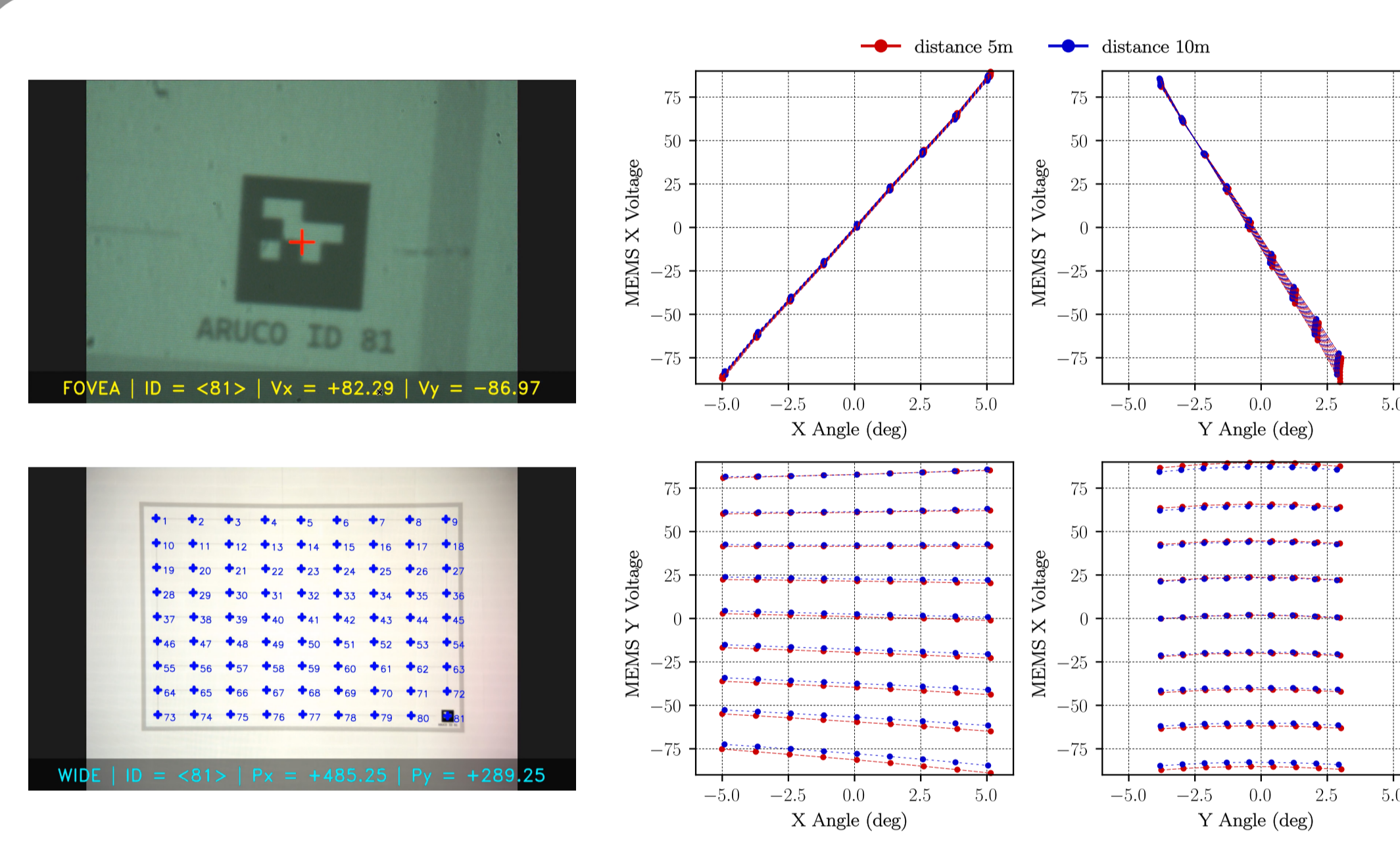

## Optical Diagram

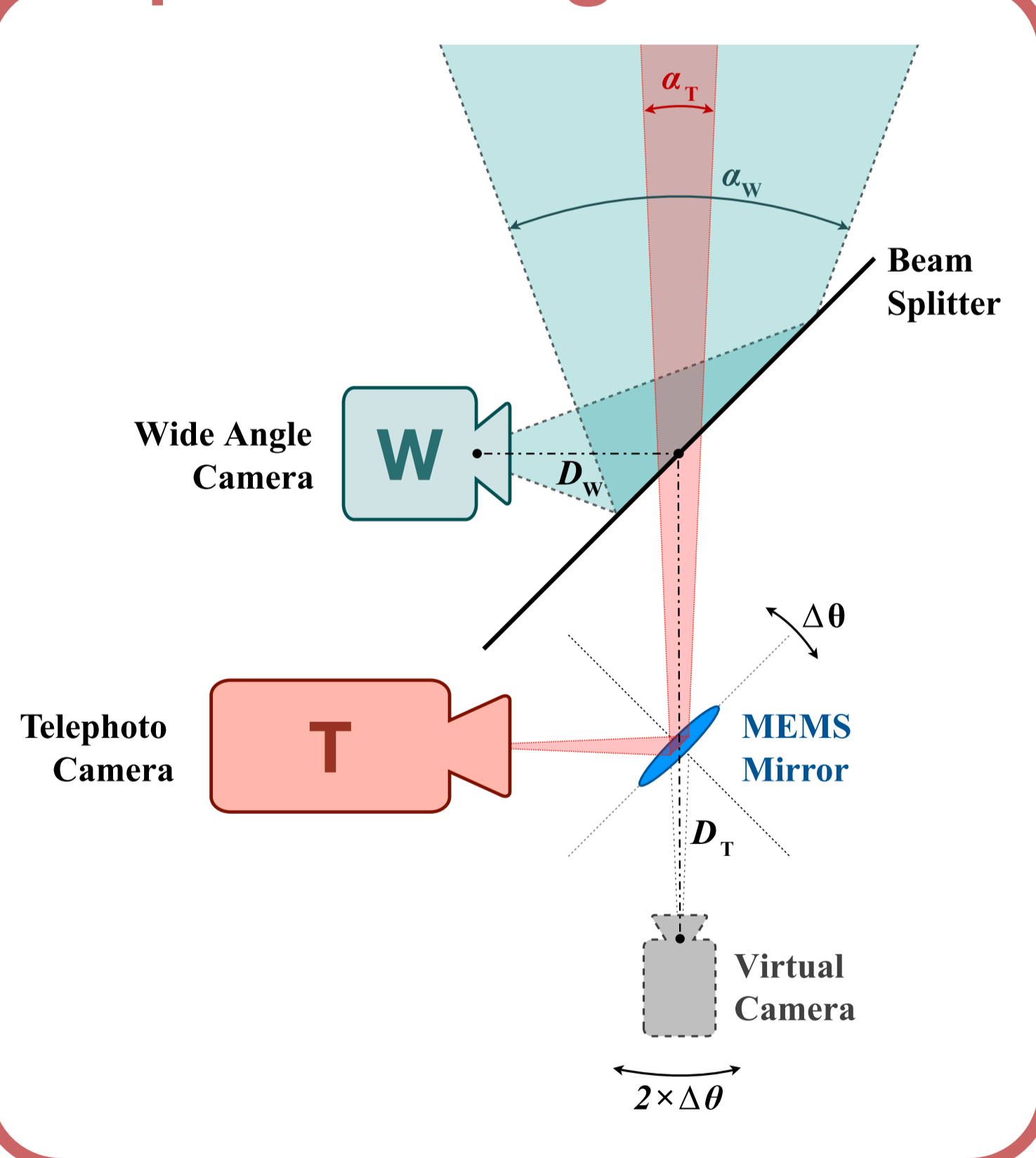

## Multi-target Tracking

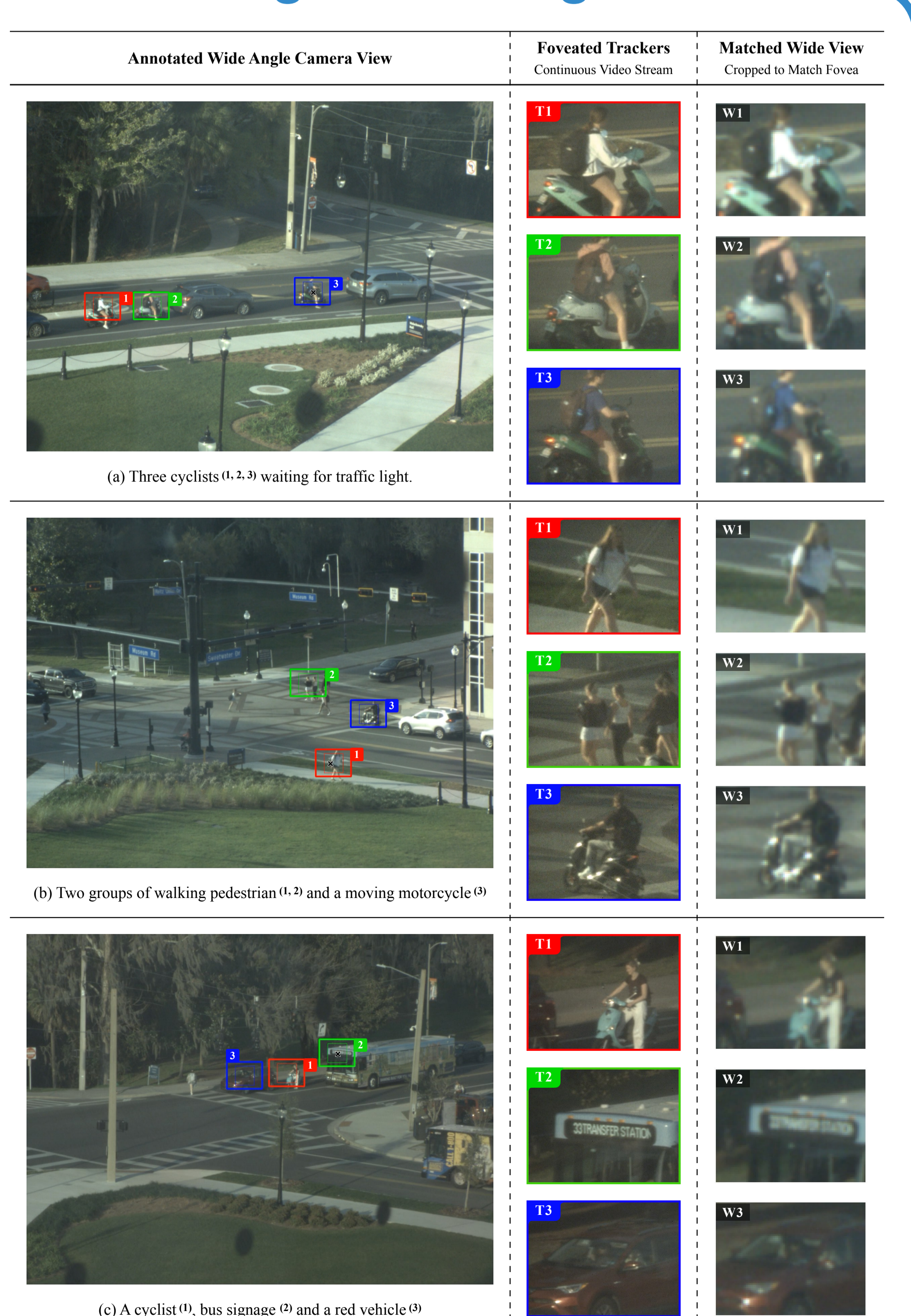

## Camera Stabilization

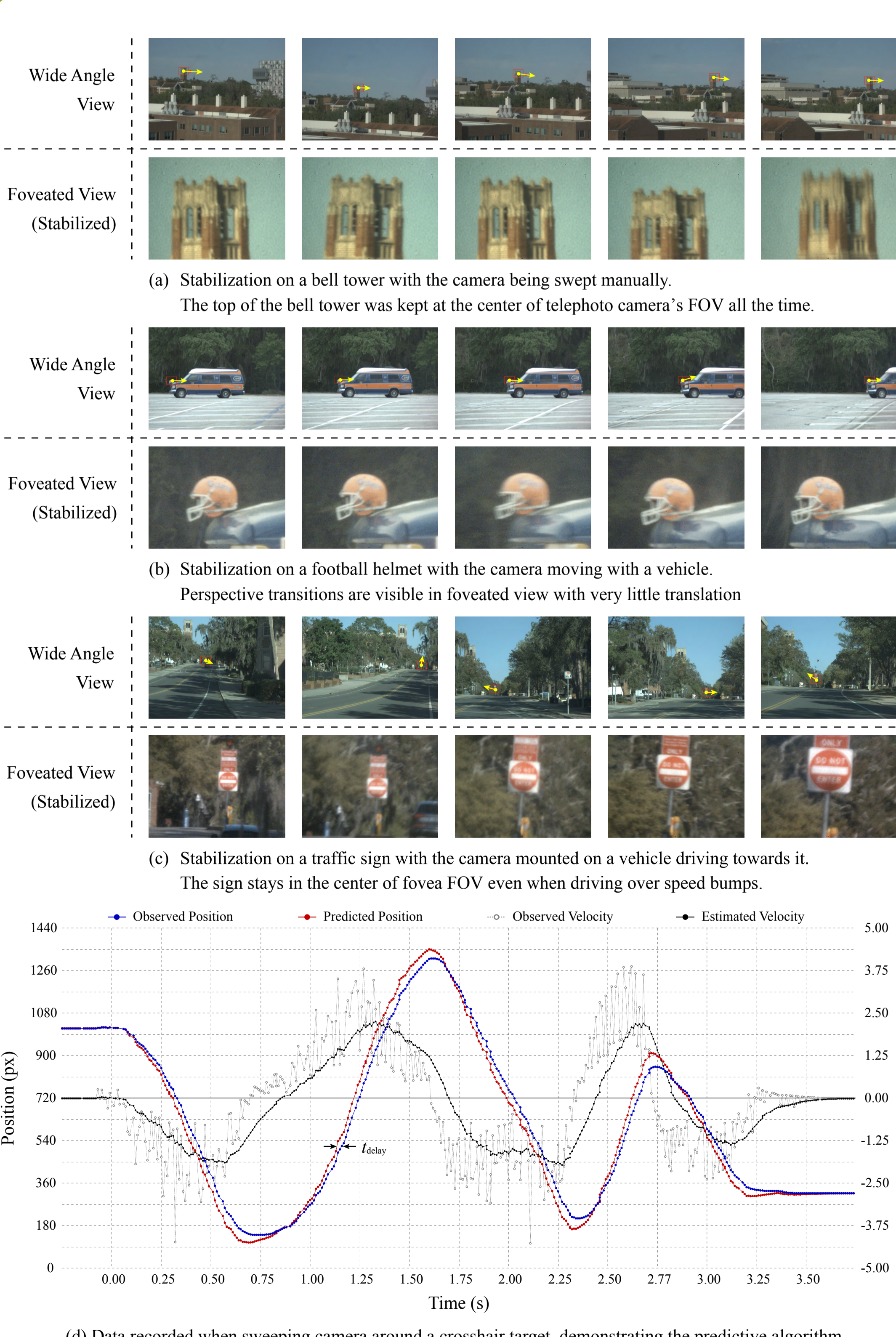

## Synchronization

